

**EXHIBIT “A”  
TO  
~~SECOND-THIRD~~ AMENDED AND RESTATED RULES OF  
ON TOP OF THE WORLD CONDOMINIUM ASSOCIATION, INC.**

**TABLE OF CONTENTS**

| <b><u>RULE</u></b>   | <b><u>PAGE</u></b> |
|--|--------------------|
| 1. Use of Common Areas .....   | <del>111</del>     |
| 2. Residential Occupancy, Use and Maintenance of Units .....               | <del>111</del>     |
| 3. Employees and Vendors .....   | <del>221</del>     |
| 4. Animals.....  | 2                  |
| 5. Alterations, Additions or Changes .....                                 | <del>332</del>     |
| 6. Disturbance or Interference .....                                       | <del>432</del>     |
| 7. Garbage and Trash.....  | <del>443</del>     |
| 8. Signs, Advertising or Notices.....                                      | <del>443</del>     |
| 9. 55 and Older Community .....  | <del>553</del>     |
| 10. Leasing and Sales of Units .....                                       | <del>554</del>     |
| 11. Notices .....  | <del>775</del>     |
| 12. Solicitation.....  | <del>775</del>     |
| 13. Private Streets and Parking.....                                       | <del>776</del>     |
| 14. Loading and Unloading .....  | <del>887</del>     |
| 15. Hurricane Shutters .....   | <del>887</del>     |
| 16. Fee Schedule.....  | <del>997</del>     |
| 17. Storage Rooms.....   | <del>10107</del>   |
| 18. Reasonable Accommodation and Modification Practices and Policies ..... | <del>11118</del>   |
| 19. Unit Owner Audio and Video Recording at Association Meetings .....     | <del>11118</del>   |
| (a) Distractions Prohibited .....  | <del>11118</del>   |
| (b) Placement of Equipment.....  | <del>12129</del>   |
| (c) Stationary Equipment .....   | <del>12129</del>   |
| (d) Notice of Recording .....  | <del>12129</del>   |

|   |               |
|---|---------------|
| 20. Inspection of the Official Association Records.....                             | <u>12129</u>  |
| (a) Inspection Requests .....   | <u>12129</u>  |
| (b) Notice of Inspection Request.....   | <u>12129</u>  |
| (c) Date and Time of Inspection .....   | <u>12129</u>  |
| (d) Records to be Inspected.....  | <u>12129</u>  |
| (e) Unit Owner Information .....  | <u>12129</u>  |
| (f) Hours of Inspection .....   | <u>13139</u>  |
| (g) Limitations.....  | <u>13139</u>  |
| (h) Reproduction Costs .....  | <u>13139</u>  |
| 21. Unit Owner Participation at Unit Owner Meetings.....                            | <u>121410</u> |
| (a) Written Request .....   | <u>131410</u> |
| (b) Notice of Participation Request.....  | <u>131410</u> |
| (c) Topic of Participation .....  | <u>131410</u> |
| (d) Limitation on Participation.....  | <u>131410</u> |
| (e) Length of Participation .....   | <u>131410</u> |
| (f) Board Discussion.....   | <u>131410</u> |
| (g) Recognition by Chairperson .....  | <u>141410</u> |
| (h) Prohibited Activities .....   | <u>141410</u> |
| 22. Unit Owner Participation at Board of Administration and Committee Meetings..... | <u>131410</u> |
| (a) Written Request .....   | <u>141410</u> |
| (b) Notice of Participation Request.....  | <u>141510</u> |
| (c) Topic of Participation .....  | <u>141510</u> |
| (d) Limitation of Participation .....   | <u>141510</u> |
| (e) Length of Participation .....   | <u>141511</u> |
| (f) Board or Committee Discussion.....  | <u>141511</u> |
| (g) Recognition by Chairperson .....  | <u>151511</u> |
| (h) Prohibited Activities .....   | <u>151511</u> |
| 23. Encumbrances and Community Service Fee.....                                     | <u>141511</u> |
| (a) Limitation on Encumbrances.....   | <u>151511</u> |
| (b) Payment of Community Service Fee .....  | <u>151611</u> |
| 24. Activity Cards.....   | <u>151611</u> |
| 25. Approvals and Consents .....  | <u>151612</u> |
| 26. Enforcement .....   | <u>161612</u> |
| 27. Severability.....   | <u>161612</u> |
| 28. Prior Rules Superseded.....   | <u>161612</u> |

Exhibits:

A - Community Standards for Alterations or Additions to the Common Areas

~~B - Hurricane Shutter Specifications~~

~~C - Schedule of Fees~~

~~D - Methodology for Allocating Space in Storage Rooms~~

C - Schedule of Fees

## SECOND-THIRD AMENDED AND RESTATED RULES OF

### ON TOP OF THE WORLD CONDOMINIUM ASSOCIATION, INC.

These are the Rules of On Top of the World Condominium Association, Inc., a Florida not-for-profit corporation. -All references in these Rules to the “**Board**” shall mean the Board of Administration of the Association. -Except as otherwise provided in these Rules, or as required by applicable law, these Rules will be implemented and administered by the management company (the “**Management Company**”) engaged or appointed by the Association. -Accordingly, the Association and the Management Company are severally and collectively referred to as the “**Association**” in these Rules.

These Rules apply to all of the On Top of the World condominium community located in Clearwater, Florida (“**On Top of the World**”). -Each owner and resident of a condominium unit in On Top of the World, and each visitor to On Top of the World, shall be bound, and shall abide, by the provisions of the applicable Declaration of Condominium, the Amended and Restated By-Laws of the Association, the deed applicable to the unit, these Rules, and all other documents relating-related to the use and operation of On Top of the World, as said documents may be amended from time to time. ~~Each owner shall be responsible for the condition of the owner’s unit regardless of (1) any delegation of responsibility the owner may have made; or (2) whether a prior owner or occupant may have contributed to the condition of the unit.~~

**1. Use of Common Areas.** Common areas and common elements of the community (jointly and severally referred to as the “Common Areas”), including but not limited to the grounds, streets, parking areas, sidewalks, walkways, balconies, entrances, halls, passages, stairways, and corridors, shall not be obstructed or encumbered and they shall be used only for the purposes intended. - No owner, resident, or visitor shall place anything in a position in which it could fall, or allow anything ~~whatever~~ to fall, from any window or door of any unit, nor shall any owner, resident, or visitor sweep or throw any dirt, liquid, or other substance from any unit into any of the corridors, halls, or elsewhere in the building or upon the Common Areas.

No garbage cans, supplies, or other articles belonging to any unit owner, resident, or visitor shall be placed either temporarily or permanently outside any unit. - Nothing shall be hung from the windows or balconies, or placed upon the window sills. - No items, including, but not limited to, No linens, cloths, clothing, curtains, rugs, or mops shall be shaken or hung from any of the windows, doors, or rails. - ~~Each owner and resident shall keep and maintain his or her unit, including but not limited to, all internal surfaces within or bounding the unit and all fixtures and equipment located in the unit, in good, presentable, clean, sanitary, and operating condition and repair.~~ - No walkways or fire exits shall be obstructed in any manner. No drying of laundry will be permitted outside any unit except in the laundry room.

Replacement of unit numbers is the responsibility of the Management Company. Unit numbers may not be changed without prior Association approval. The Association shall have the authority to make, or cause to be made, any additional capital improvements upon the Common Areas necessary to provide facilities or services specifically designed to meet the requirements of the Fair Housing Act, as amended, and other applicable laws.

**2. Residential Occupancy, Use and Maintenance of Units.** Each unit shall be used for occupancy by a single family and for no other use or purpose without the prior written consent of the Association. -Without limiting the generality of the preceding sentence, no unit may be used for business

or professional purposes except as may first be consented to in writing by the Association. - Occupancy by a single family shall mean and refer to one ~~or more persons, related by blood, adoption or marriage,~~ (1) natural person or not more than two ~~so unrelated~~ (2) natural persons residing who customarily reside and live together as a single housekeeping unit, and otherwise hold themselves out as a family unit, whose legal residence is the residential unit; provided, however, in the event an owner is the designated caregiver of a dependent or disabled individual, then the term "single family" shall include such additional dependent or disabled individuals. The Association defines a visitor as an individual who temporarily occupies a unit for a period not to exceed three ~~(3) consecutive weeks annually~~ (3) consecutive weeks in any twelve (12) month period. ~~Each owner and resident shall keep and maintain his or her unit, including but not limited to all internal surfaces within or bounding the unit and all fixtures and equipment located in the unit, in good, presentable, clean, sanitary and operating condition and repair.~~

**3. Use and Maintenance of Units.** Each owner shall be responsible for the condition of the owner's unit regardless of (1) any delegation of responsibility the owner may have made; or (2) whether a prior owner or occupant may have contributed to the condition of the unit. Each owner and resident shall keep and maintain his or her unit, including but not limited to, all internal surfaces within or bounding the unit and all fixtures, including plumbing, and equipment servicing that unit exclusively located in the unit, in good, presentable, clean, sanitary, and operating condition and repair. The balconies, porches, and terraces shall be used only for purposes intended and shall not be used for hanging garments or other objects, or for cleaning rugs or other household items. No owner, resident, or visitor shall place anything in a position in which it could fall, or allow anything whatever to fall, from any window or door of any unit, nor shall any owner, resident or visitor sweep or throw from any unit any dirt or other substance from any unit into any of the corridors, halls, or elsewhere in the building or upon the Common Areas. No drying of laundry will be permitted outside any unit except in the laundry room.

Upon request from the Association, entry to the unit shall be granted to the Association or Management Company to perform repairs, emergency services, and/or maintenance within the unit if needed to minimize damage to Association owned property or common elements which the Association has an obligation to maintain. Owners shall be responsible for securing their units (including outside patios) prior to a storm watch or warning.

**3.4. Employees and Vendors.** Owners, residents, tenants, and their guests and tenants shall treat all employees and vendors of the Association and Management Company with dignity and respect and shall refrain from attempting to direct, or to assert control over the activities of, any employee or vendor of the Management Company or the Association. Shouting or using profanity, making derogatory comments, or behavior otherwise disruptive in nature will not be permitted.

**4.5. Animals.** No livestock, birds, poultry, reptiles, or other animals of any kind shall be raised, bred, or kept in On Top of the World by any occupant of a unit except for a reasonable number of dogs, cats, birds, or other usual and customary household pets kept or maintained solely as domestic pets and not for any commercial purpose. Animals brought into On Top of the World must be well behaved. Any breed or variety of dog, cat or other animal deemed especially aggressive or offensive, and any threatening or disruptive animal, as determined by the Association in its sole and absolute discretion, may be excluded from On Top of the World.

While outside the unit, all animals must be kept on a leash or other restraint and must be accompanied at all times by the owner. - ~~(Tethering and leaving your dog outside and leaving them~~ is a violation of

Pinellas County ~~Code~~, Animal Services Ordinance. ~~Animal feces must be picked up~~ Animal owners must pick up animal feces immediately and disposed of it properly. ~~by the owner or custodian.~~ The application, interpretation and enforcement of this rule is subject to the Association's reasonable accommodation and modification policies and practices and applicable law. No animal shall be allowed to make an unreasonable amount of noise or otherwise ~~to~~ become a nuisance. Any animal deemed too noisy, aggressive, offensive, threatening, disruptive, or otherwise an actual or potential nuisance, as determined by the Association in its sole and absolute discretion, may be excluded from On Top of the World Community by the Association. ~~In addition, upon the written request of any occupant, the Board may conclusively determine, in its sole and absolute discretion, whether or not, for purposes of this section, a particular animal is a usual and customary household pet and/or whether or not a particular animal is too noisy, aggressive, offensive, threatening, disruptive or otherwise an actual or potential nuisance. The Board shall have the right to require the owner of any animal deemed by the Association to be too noisy, aggressive, offensive, threatening, disruptive or otherwise an actual or potential nuisance to remove such animal from the Community.~~

Each Owner shall be liable to the Association for the cost of repair of any damage to the Common Areas caused by any animal belonging to such Owner or to any Occupant of such Owner's Residential Unit. The application, interpretation, and enforcement of this rule is subject to the Association's reasonable accommodation and modification policies and practices and applicable law.

**5.6. Alterations, Additions, or Changes.** Except to the extent required to be permitted under applicable law, no alteration, addition, replacement, or removal may be made or maintained to, on or from any of the following areas or improvements ~~of within the~~ On Top of the World community without the prior written consent of the Association: (a) the Common Areas, ~~(including but not limited to the roof or exterior of any building or the exterior, door or window of any unit), such as but not limited to any alteration, addition, replacement or removal of any painting, awning, wire, pipe, light, slab of concrete or other permanent material, antenna, satellite dish or other equipment, device or projection;~~ (b) any structural element of any building located within the boundaries of any unit; ~~or~~ (c) any other improvement located within the boundaries of any unit for which the Association may have maintenance and repair responsibility or which, if altered, added, replaced, or removed may adversely affect another unit or unit owner, ~~such as but not limited to any wire, pipe, heating/air conditioning duct, wall or partition.~~

Any alteration, addition, replacement, or removal ~~not consented to~~ approved in writing by the Association is subject to correction by the Association without notice or compensation, ~~to the owner~~ and the owner who causes the unauthorized alteration, addition, replacement, or removal shall be responsible to be made or maintained shall reimburse the Association for all costs and expenses ~~so incurred. incurred.~~ An exterior compliance inspection will be performed prior to ownership transfer. Any alteration, addition, replacement, or removal not approved by the Association, regardless of its origin, must be corrected by the current owner before the Association will approve the ownership transfer.

~~This rule is subject to the limitations that it shall not be applied or enforced in any manner that contravenes applicable law; and the application, interpretation, and enforcement of this rule is subject to the Association's reasonable accommodation and modification policies and practices and applicable law. Please also refer to Exhibit "A" attached to and constituting part of these Rules which sets forth the Community Standards for Alterations and Additions to the Common Areas of On Top of the World.~~

**6.7. Disturbance or Interference.** No occupant ~~nor or~~ their guests, shall do or permit to be done anything that interferes with the rights, comfort, or convenience of any other owner, resident, or visitor. No improper, unsanitary, unsightly, offensive, or unlawful use, condition, or activity shall be permitted, conducted, or maintained in On Top of the Community World. ~~by any occupant or occupant's guests, and all applicable governmental laws and regulations shall be observed.~~ No nuisances ~~shall be allowed, nor use or practice,~~ which ~~is~~ may be the source of an annoyance to occupants; or ~~which may~~ interferes with the peaceful possession of any other occupant within On Top of the Community World shall be permitted. All applicable governmental laws and regulations shall be observed. The Association does not interfere with or mediate disputes between neighbors.

~~The Use,~~ enjoyment, and occupancy of On Top of the Community World shall be carried out in such a manner as not to cause or produce any of the following effects discernible outside buildings ~~located thereon~~ or affect the adjoining property ~~or any portion or portions thereof:~~ (a) noise or sound that exceeds the levels permitted under the Pinellas County Noise Ordinance, as amended from time to time; (b) offensive or abusive language, behavior, or acts; (c) smoke, noxious, toxic, or corrosive fumes or gases; (d) obnoxious odors; (e) dust, dirt, or fly ash; (f) unusual fire or explosive hazards; or (g) vibration. ~~Without limiting the generality of the preceding sentence,~~

~~No~~ owner, resident, or visitor may create a noise nuisance or use, ~~or~~ play, or permit to be used or played, in any unit or elsewhere in On Top of the World any mechanical, electrical, or other device ~~(including but not limited to any musical instrument, stereo, amplifier, radio or television) in a manner that disturbs any other owner, resident, or visitor of On Top of the World~~ between the hours of 11:30 PM p.m. and ~~the following~~ 7:00 AM a.m. ~~in a manner that disturbs any other owner, resident or visitor in On Top of the World.~~

~~-~~Skateboarding, skating, rollerblading, biking, and similar activities are permitted only within the streets ~~at in~~ On Top of the World and shall not be permitted in any other Common Areas of On Top of the World.

For the purposes of interpreting and implementing this section, the Board shall have exclusive and absolute authority to determine whether or not any existing or proposed activity or condition violates this section.

**7.8. Garbage and Trash.** Routine disposal of garbage and trash shall be accomplished only by use of the receptacles provided by the Association. ~~-~~ No garbage or trash shall be left outside of such receptacles, units, common elements, or trash rooms. ~~-~~ There shall be no disposal within On Top of the World of any unusual or excessive garbage or trash generated from within any unit ~~(including but not limited to clothing, household furnishings, or construction debris.)~~ except in drop storage containers, construction debris containers, or dumpsters provided by third parties at no cost to the Association and in compliance with Rule 14 of these Rules.

**8.9. Signs, Advertising, or Notices.** Each unit may identify its resident(s) by a name plate of a type and size approved in writing by the Association and mounted in a place and manner so approved. ~~-~~ No signs, advertising, or notices of any kind or type, including but not limited to "for rent", ~~or~~ "for sale", ~~signs,~~ "political", "open house", "estate sale", ~~or notices~~ others similar in nature, shall be permitted or displayed on the exterior of any unit, ~~or~~ on any building, vehicle, or Common Areas in On Top of the World, nor shall the same be permitted or displayed in such a manner as to be visible from the exterior of any unit, ~~without the prior written consent of the Association.~~ ~~-~~ Stickers or signage, not to exceed

2"x6", advising of ~~the~~ special needs, such as but not limited to "oxygen in use", are permitted in the nearest corner of the window near closest to the front entrance of the unit, ~~with prior written approval of the Association.~~

**9.10. 55 and Older Community.** On Top of the World has been designated as housing for persons who are fifty five (55) years of age or older. ~~-At least eighty percent (80%) of the units in On Top of the World must be occupied by at least one person who is fifty five (55) years of age or older.~~

In order to ensure that On Top of the World qualifies as housing for persons 55 years of age or older under the Federal Fair Housing Act (42 U.S.C. 3601, et seq.), satisfies the occupancy and age verification requirements of Rule 100.307 of the U.S. Department of Housing and Urban Development (24 C.F.R. 100.307), and complies with the requirements of the Florida Fair Housing Act (Chapter 760, Florida Statutes) and the rules and regulations of the Florida Commission on Human Relations, a survey of the residents of On Top of the World will be conducted and updated by the Association as and to the extent required by applicable law. Each owner shall cooperate with the Association in its efforts to comply with the requirements of the abovementioned acts and rules and regulations, and with all other applicable laws. ~~-Such cooperation shall include (but shall not be limited to) providing to the Association, within ten (10) days after written request, such information (such as but not limited to identification of whether at least one resident of the unit is fifty five (55) years of age or older and the current age or date of birth of such person) and signed surveys, sworn affidavits, certifications, and other reliable, legally sufficient documentation as may be required from time to time by the Association. No child minor under the age of seventeen (17) eighteen (18) years shall be allowed permitted to reside in any unit. -The Association shall have the authority to make any additional capital improvements upon the Common Areas necessary to provide facilities or services specifically designed to meet the requirements of the Fair Housing Act, as amended, and other applicable laws.~~

~~No child under the age of seventeen (17) years shall be allowed to reside in any unit. -A unit owner who owns and occupies his or her own unit may permit one (1) minor only to reside in the unit with him or her, but only if the minor is at least seventeen (17) years of age and a member of that owner's family. The test for residency by minors shall be either (a) residency in any unit for any period exceeding one (1) month, accompanied by enrollment in a public or private school or institution located within Pinellas County, Florida, or (b) residency in any unit for a cumulative period of six (6) months or longer.~~

~~The Association shall have the authority to make any additional capital improvements upon the Common Areas necessary to provide facilities or services specifically designed to meet the requirements of the Fair Housing Act, as amended, and other applicable laws.~~

Notwithstanding the foregoing, in the event any modification to the Federal Act and the Florida Act which would make less restrictive the requirements for eligibility for the exemption for "housing for older persons" provided by both the Federal and Florida Acts, then, in such event, those less restrictive standards may, in the sole discretion of the Board, be adopted by the Board alone and shall supersede and replace the eighty percent (80%) occupancy standard described herein.

**10.11. Leasing and Sales of Units.** No unit may be occupied, leased, ~~or sold,~~ inherited, or deed changed without the prior written approval by the Association ~~of the occupant, lessee, or new owner. -Without limiting the generality of the foregoing, the~~ The Association shall have the right, in its sole and absolute discretion, to deny approval of any proposed ownership transfer or occupancy, ~~lease or sale if, following the taking of the proposed occupancy, making of the proposed lease or closing of the proposed sale,~~



~~theif the~~ unit will not be occupied by at least one (1) person who is fifty five (55) years of age or older. As a condition precedent to consideration for approval, each prospective owner or occupant, lessee and purchaser must (a) inform the Association in writing whether the unit will be occupied by at least one (1) person who is fifty five (55) years of age or older; (b) appear for an interview with a designated representative of the Association; and (c) submit to a background screening check to be arranged by the Association.

Approval of a tenant ~~shall be~~ for the initial term lease of the a unit (or renewal of any lease only and for a unit) must be approved in writing by the Association prior to commencement of the lease term (or renewal thereof). ~~occupancy by the tenant beyond the initial term is subject to approval by the Association. Regardless of the Association's action on any proposed occupancy, lease, or sale of a unit, the Association and its agents, employees, and delegates are not responsible for the actions of any occupant of On Top of the World. In no event may any unit be leased in a furnished condition for a term of less than six (6) months plus one (1) week and no unit may be leased unfurnished for a term of less than one (1) year. -A lease, whether new or renewed, may not exceed a maximum of one (1) year in length. Units may only be occupied in their entirety and no fraction or portion of a unit may be leased. Unit owners must relinquish their Activity Card(s) prior to the start of a lease term. Simultaneous usage of an Activity Card by a unit owner and a tenant is prohibited.~~

~~No person shall be denied the right to purchase, lease or occupy a unit because of race, religion, sex, national origin, marital status, sexual orientation, gender or disability.~~

~~In no event may any unit be leased in a furnished condition for an initial term of less than six (6) months plus one (1) week, and no unit may be leased in an unfurnished condition for an initial term of less than one (1) year. Units may be leased, licensed or occupied only in their entirety, except as described in the following paragraph, and no fraction or portion of a unit may be rented. Individual rooms of a unit may not be leased on any basis. Notwithstanding the foregoing, the father, mother, sibling or child of the owner may also reside in the unit provided that all other occupancy restrictions and requirements are met.~~

Occupancy of any condominium unit owned by any corporation, limited liability company, partnership, limited partnership, limited liability partnership, limited liability limited partnership, trust or other form of artificial entity shall be limited to any person who: (a) is fifty five (55) years of age or older; (b) currently holds a title and senior management position with that artificial entity or currently owns (directly or indirectly) at least a ten percent (10%) beneficial interest in that artificial entity; (c) is an authorized signatory on the principal bank account of that artificial entity; ~~AND and~~ (d) has ~~had either~~ (i) his or her name, title and senior management position; or (ii) ten percent (10%) or more beneficial interest registered by the artificial entity with the Association, in writing, not less than forty five (45) days prior to first occupancy of the unit by such person. -Not more than four (4) persons meeting the foregoing criteria may be registered with the Association for occupancy of a condominium unit at any one point in time. -In addition, no single artificial entity, and no two or more artificial entities under direct or indirect common ownership or control, may own or control, whether directly or indirectly, more than three (3) condominium units in On Top of the World at the same time. The preceding provisions shall take effect on July 1, 2004, shall apply prospectively from and after that date and shall not prohibit the continuation of any occupancy, ownership or control existing on that date.

The Association may, ~~initiate and pursue (but is shall not be obligated to initiate or pursue),~~ any legal or equitable action or other lawful means to remove from any unit any person whose occupancy has not previously been approved in writing by the Association. Regardless of the Association's action, the Association and its agents, employees, and delegates are not responsible for the actions of any owner or

occupant of On Top of the World. No person shall be denied the right to own, lease, or occupy a unit because of race, religion, sex, national origin, marital status, sexual orientation, gender, or disability.

Simultaneous usage by a unit owner and a tenant of the Common Areas otherwise readily available for use generally by unit owners is prohibited. Activity Cards shall be issued to tenants in accordance with the SCA Facilities Rules and Regulations (as same may be amended from time to time).

~~Notices. All official notices from the Association must be approved in writing by the Chairman or Vice Chairman of the Association and shall bear the signature of a member of the Board. Except as otherwise required by the Amended and Restated By-Laws of the Association or applicable law, all such notices shall be mailed to each unit owner at the address on file for such purpose with the Association. Notices of meetings of the Board shall be posted on the bulletin board at the East Activity Center located at 2069 World Parkway Boulevard East or on the community information channel. No member of the Association (other than a duly authorized member of the Board of Administration or the president or vice president of the Association) shall make or permit to be made, any written, typed or printed notice of any kind, or post the same on any bulletin board, or mail or otherwise circulate the same to any other Association member, which purports or represents to be an official act or notice of the Association. Notices of a social nature or purpose sent to other members by a member, in his or her personal capacity, will not be deemed to be official notices from the Association, but they must bear the signature of the member or members making or uttering such notices and they shall be fully responsible for the contents thereof. All notices to the Association shall be sent to 2069 World Parkway Boulevard East, Clearwater, Florida 33763 or such other address or addresses as may be designated from time to time by written notice from the Association to the unit owners.~~

**11.12. Solicitation.** In order to promote a harmonious community and to minimize disturbing resident's<sup>2</sup> quiet enjoyment of their units, solicitation within On Top of the World by vendors, service companies or any owners, residents, or visitors is strictly prohibited without the prior, written consent of the Association. -This includes solicitation on behalf of political campaigns, political candidates, voter awareness groups, petitions for governmental action, civic organizations, service clubs, school groups, charitable organizations, religious organization, etc. -Notwithstanding the foregoing, nothing herein prohibits representatives from the Association from contacting ~~O~~owners and residents in their units.

**12.13. Private Streets and Parking.** The streets and parking areas of On Top of the World are private. No unregistered motor vehicles, no motor vehicles with expired registration, and no abandoned motor vehicles (whether or not currently registered) are permitted at any time in On Top of the World.- Any motor vehicle that remains unmoved for a period of fifteen (15) days or more may be treated by the Association as having been abandoned and the Association may arrange for it to be towed unless the owner ~~thereof~~ first notifies the Association in writing of the owner's intent to leave the vehicle unmoved for a longer period of time and the Association consents in writing to such longer period of time. When deciding whether a motor vehicle may remain unmoved for longer than fifteen (15) days, the Association shall consider whether doing so presents a public safety concern.

No vans, trailers, commercial vehicles, storage/debris containers, or containers of any kind (including but not limited to commercial trucks, vans, trailers, drop storage containers, construction debris containers and dumpsters) and no recreational vehicles of any kind (including but not limited to RVs, campers, trailers and boats) may be parked overnight in On Top of the World without the prior written

consent of the Association. -The preceding sentence does not apply to any vehicles or containers brought into On Top of the World incidental to any maintenance or repair activities undertaken by the Association. -The Association may designate ~~(but shall not be obligated to designate)~~, in writing, approved areas for placement of such vehicles or containers ~~in On Top of the World.~~

Only vehicles belonging to the Association, related entities, or ~~current residents approved occupants~~ of On Top of the World and their ~~respective~~ visitors ~~(for the durations of their visits)~~, and ~~not otherwise prohibited under the preceding paragraphs~~, may ~~enter or~~ park on any of the streets or parking areas ~~of On Top of the World.~~ ~~Each owner or resident who regularly drives or maintains a motor vehicle within the community must display a “vehicle identification” in the form prescribed by the Association. Such vehicle identification shall remain the property of the Association.~~ Street parking is available on streets not designated with “No Parking” signage. Parking is not permitted in fire lanes, multimodal lanes (bike/walking lanes), or in common areas. Common Areas not designated for Visitor parking. Visitor parking is reserved for visitors to the community on a first come, first served basis. ~~and It is not intended for indefinite use by one party.~~

All motor vehicles shall be parked only in the parking spaces designated for that purpose by the Association. ~~Such designation may be by separate letter or appropriate marking of the parking space or spaces by the owner’s or resident’s last name or unit number.~~ No stop block may be placed in any parking space without the prior approval of the Association. Reserved parking spaces are designated by unit number. A request for a parking space change must be submitted to the Association in writing accompanied by a drawing that indicates the current parking space and the requested replacement parking space. -If the parking space involves an exchange of assigned parking spaces, both owners must agree to the exchange in writing. -Parking space assignments are subject to change by the Association pursuant to its reasonable accommodation policies and practices and applicable law.

The Association shall have the authority, but not the obligation, to have any vehicle that violates this rule removed from On Top of the World, without compensation or notice to anyone except as may be required by applicable law.- None of the Association, the members of the Board, the Management Company, or any officer, director, employee, or agent of the Association or the Management Company shall have any liability to any vehicle owner for any action taken by any of them pursuant to this rule.

**13.14. Loading and Unloading.** No loading or unloading of trucks, trailers, drop storage containers, construction debris containers, dumpsters, vans, or similar vehicles or containers shall be permitted in On Top of the World during non-daylight hours or on Sundays or legal holidays without the prior written consent of the Association. -Anyone requesting overnight parking ~~such consent~~ shall also be required to apply to the Association, in writing or via email at associationinfo@otowfl.net, not less than ~~forty eight~~ seventy-two (4872) hours prior to the date requested on which the loading or unloading is to occur. The ~~request~~ application for consent must contain a statement showing reasonable cause for the ~~request~~ consent to be granted. ~~and must also contain the names and residence addresses and driver’s license numbers of each all person(s) who will enter On Top of the World for the purpose of loading or unloading any vehicle or container.~~ -Any person loading or unloading any vehicle or container in violation of this rule shall be considered to be trespassing in On Top of the World.

**Hurricane Shutters.** ~~The Board shall, from time to time, establish hurricane shutter specifications that comply with the applicable building code, and establish permitted colors, styles, materials and installation standards for hurricane shutters. Subject to the provisions herein, the Association shall~~

~~approve the installation or replacement of hurricane shutters conforming to the specifications adopted by the Board. Owners shall be responsible for securing their units (including outside patios) prior to a storm watch or warning. Any damage to the building structure or interior of the home resulting from either the installation of or the use of storm shutters shall be promptly repaired by the Owner. The Association shall have no obligation with respect to the installation of the shutters, and/or for the repair, replacement and/or upgrade of the shutters. All shutters shall comply with the specifications set forth on Exhibit "B" attached to and constituting part of these Rules.~~

~~Fee Schedule. Attached hereto as Exhibit "C" and constituting part of these Rules is a schedule of fees and charges to be levied by the Association in connection with specified services or circumstances. The Association shall have the discretion to waive or reduce any fee in any particular case if, in the opinion of the Association, it is justified by hardship or other special circumstance.~~

#### **15. Encumbrances and Community Service Fee.**

**a. Limitation on Encumbrances.** ~~No owner may mortgage or otherwise encumber his or her unit, or any interest in it, without the written approval of the Association, except to a national bank, state bank, life insurance company, or federal savings and loan association or seller of the unit. Total mortgage debt, home equity loans, and other indebtedness secured by liens encumbering any unit may not at any time exceed neither the limit set forth in the applicable Declaration of Condominium. In the absence of a limit specified in the Declaration of Condominium, the amount defaults to sixty-five percent (65%) of the purchase price paid for the unit by the owner. Reverse mortgages are not permitted.~~

~~the limit set forth in the applicable Declaration of Condominium; nor~~

~~an amount equal to sixty five percent (65%) of the lesser of (a) the purchase price paid for the unit by the owner, or (b) the appraised value of the unit as certified in writing by a Florida licensed real estate appraiser.~~

**b. Payment of Community Service Fee.** ~~From time to time the Association may designate the method of payment of the Community Service Fee, Assessments, Lease Payments, or other amounts payable to the management company. Effective for all acquisitions of units occurring after June 24, 2004, and continuing thereafter unless and until otherwise designated by the Association, the method of payment shall be by electronic transfer, also known as a Automated Clearing House (ACH) debit or auto debit, from a U.S. Bank in U.S. Dollars.~~

**16. Activity Cards.** ~~The right to use the recreation facilities is limited solely to the current lawful approved occupant(s) of the unit. (i.e., the owners or any renters approved by the Association in accordance with Rule 10 entitled "Leasing and Sales of Units.") Activity Cards will be issued solely to approved owners who reside full-time or part-time in their units, upon presentation of proof of ownership, or to approved renters tenants who have been approved by the Association pursuant to Rule 1011. One (1) Activity Card shall be allocated to each approved occupant as provided by the Rules and Regulations and up to a maximum of two (2) Activity Cards per unit.~~

~~Activity Cards must be presented upon request while utilizing the recreational facilities. An owner or approved renter tenant with a valid Activity Card must accompany any guest using any recreational facilities. Simultaneous usage by a unit owner and a tenant of the recreation facilities is prohibited. To obtain a new Activity Card, to renew a current Activity Card, or to have a replacement Activity Card~~

issued, please see visit the Community Service Office, and bring with you You must present a current driver license or other government issued photo ID card, a current piece of mail with your name and unit address, and remit the appropriate fee (see Fee Schedule in Exhibit "C").

**17. Storage Rooms.** The Common Elements of each condominium building include one or more storage rooms ~~(each, a "Storage Room"). No personal property of any unit owner or occupant may be placed in any Storage Room without the prior approval of the Association.~~ The Association will allocate to each unit a portion of the building's Storage Room floor area ~~in the Storage Rooms in the applicable building~~ in accordance with the methodology set forth ~~on in Exhibit "D"~~ Exhibit "B" attached hereto and constituting part of these Rules. ~~The location of the storage space allocated to each unit will be determined by the Association.~~

Storage rooms may not be used for work-shops of any kind. ~~All work spaces currently in existence and installed by unit owners within the Common Areas must be removed by the applicable unit owner within thirty (30) days after receiving notice from the Association or Management Company. after the adoption of this rule.~~ The Association may (but shall not be obligated to) remove any owner-installed work station remaining in the Common Areas after the expiration of the said thirty (30) day period; at the applicable unit owner's expense, including, but not limited to, the costs of demolition, hauling, and disposal of debris and repair to the storage room.

Unit owners are responsible for maintaining their assigned storage spaces in a safe, orderly condition. No material may be placed or stored in any Storage Room in violation of applicable laws or codes. No amount of any explosive material, flammable liquid, or flammable gas (i.e. propane tank and the like), regardless of type of container, ~~including, but not limited to, any propane tank,~~ may be placed or stored in any Storage Room. ~~Boxes and containers may not be stacked in a way that presents a safety hazard to others. No owner shall cause or permit any obstruction of the central aisle in any Storage Room or use any portion of the storage area of any Storage Room not specifically assigned to that owner by the Association. No shelves may be installed in any Storage Room unless the proposed design and location of the shelves are approved by the Association prior to installation.~~

The assignment of a specific portion of a Storage Room for the use of a particular unit shall continue indefinitely until it is withdrawn or changed by the Association; and it shall automatically pass with, and be inseparable from, the ownership of the applicable unit. ~~However, despite the continuing nature of such assignment, within thirty (30) days after ownership of any unit is transferred to a new owner, the prior owner of the unit shall remove all of the at transfer of ownership, the~~ prior owner's personal property must be removed from the Storage Room. ~~If any personal property of a prior owner remains in the Storage Room after the expiration of the said thirty (30) days period, the Association may (but shall not be obligated to) attempt to notify the prior owner of the Association's demand that the prior owner to remove all of the prior owner's personal property from the Storage Room within thirty (30) days after the date of the notice. If sent, the said notice shall be sent by hand delivery, by certified U.S. Mail, Return Receipt Requested, or by a commercial next business day courier service such as Federal Express, to the prior owner at the latest address of the prior owner set forth in the records of the Association. A copy of the notice shall also be placed on or immediately adjacent to the prior owner's personal property in the Storage Room.~~

If any personal property of a prior owner remains in the Storage Room after the expiration of the said thirty (30) day period following the date of the Association's said notice to the prior owner, all personal

property of the prior owner which remains in the Storage Room shall be deemed automatically and conclusively to have been abandoned by the prior owner and the Association shall have the option, to be exercised by the Association in its sole and absolute discretion, to do one or more of the following: (a) take and assume exclusive ownership of, and control over, the personal property, as a gratuitous transfer of title thereto, free of any right, title, interest, or claim of the prior owner, and thereafter use, sell, donate, or otherwise dispose of the personal property in any manner deemed by the Association to be in the best interest of the Association, and to retain for the benefit of the Association any monetary or other benefits derived from any such use or disposition, (b) reject ownership of the personal property, remove it from the Storage Room and store it, as agent for the prior owner and at the prior owner's expense, in a location selected by the Association until such time as it is picked up by the prior owner or the Association elects to proceed with any other option under this paragraph, or (c) cause the personal property to be destroyed, recycled, or discarded. -None of the Association, the members of the Board, the Management Company, or any officer, director, employee or agent of the Association or the Management Company shall have any liability to any prior owner for any action taken ~~by any of them~~ pursuant to this rule.

**18. Notices.** All official notices from the Association must be approved in writing by the Chairman or Vice Chairman of the Association and shall bear the signature of a member of the Board. -Except as otherwise required by the Amended and Restated By-Laws of the Association or applicable law, all such notices shall be mailed (or emailed to owners who have agreed to electronic communications) to each unit owner at the address on file for such purpose with the Association. -Notices of meetings of the Board shall be posted on the bulletin board at the East Activity Center located at 2069 World Parkway Boulevard East or on the community information channel. -No member of the Association (other than a duly authorized member of the Board of Administration or the ~~president or vice president~~ Chairman or Vice Chairman of the Association) shall make or permit to be made, any written, typed or printed notice of any kind, or post the same on any bulletin board, or mail or otherwise circulate the same to any other Association member, which purports or represents to be an official act or notice of the Association. Notices of a social nature or purpose sent to other members by a member, in his or her personal capacity, will not be deemed to be official notices from the Association, but they must bear the signature of the member or members making or uttering such notices and they shall be fully responsible for the contents thereof. -All notices to the Association and to members of the Board of Administration shall be sent to 2069 World Parkway Boulevard East, Clearwater, Florida 33763 or such other address or addresses as may be designated from time to time by written notice from the Association to the unit owners.

~~**Reasonable Accommodation and Modification Practices and Policies.** The application, interpretations and enforcement of these Rules are subject to reasonable accommodation and modification laws and the related practices and policies adopted and amended from time to time by the Board.~~

**19. Unit Owner Audio and Video Recording at Association Meetings.** Any unit owner may tape record or videotape meetings of the Board of Administration, committee meetings, or unit owner meetings, subject to the following restrictions:

- a. **Distractions Prohibited.** The only audio and video equipment and devices which unit owners are authorized to utilize at any such meeting is equipment which does not produce

distracting sound or light emissions. Anyone videotaping or recording a meeting shall not be permitted to move about the meeting room in order to facilitate the recording.

- b. **Placement of Equipment.** Audio and video equipment shall be assembled and placed in position not less than sixty (60) minutes in advance of the commencement of the meeting. The placement of audio and video equipment and devices is subject to Association approval prior to the start of the meeting.
- c. ~~**Stationary Equipment.** Anyone videotaping or recording a meeting shall not be permitted to move about the meeting room in order to facilitate the recording.~~
- d.c. **Notice of Recording.** Advance written notice shall be given to the Board of Administration not less than twenty four (24) hours prior to the Board meeting by any unit owner desiring to utilize any audio or video equipment at the meeting.

## 20. **Inspection of the Official Association Records.**

- a. **Inspection Requests.** All requests for inspection of the official records of the Association shall be in writing ~~and All requests for inspection of the records shall be delivered to the Association at the address specified in Rule 11 above either~~ 2069 World Parkway Boulevard East, Clearwater, FL. 33763- either by personal delivery or by certified mail. Each written request shall specifically outline the records which the unit owner or the unit owner's authorized representative requests to inspect. A unit owner may make or obtain copies of the records that are the subject of the unit owner's inspection at the charge of \$.25 per page, or such higher charge as may be allowed by law.
- b. ~~**Notice of Inspection Request.** All requests for inspection of the records shall be delivered to the Association at the address specified in Rule 11 above either by personal delivery or by certified mail.~~
- c.b. **Date and Time of Inspection.** The inspection shall occur at a date and time acceptable to the Association, but, unless a later date is requested or agreed to by the unit owner, not later than the ~~fifth (5th)~~ tenth (10<sup>th</sup>) working day after the receipt by the Board or its designee of the written request for inspection. ~~The unit owner may suggest up to three (3) alternative dates and times for the requested inspection for consideration by the Association.~~ At the conclusion of the records inspection, if copies are requested, the Association will provide them as soon as practical following receipt of payment from the requesting unit owner. they may be obtained within ten (10) working days of the written request inspection.
- d. ~~**Records to be Inspected.** Each written request shall specifically outline the records which the unit owner or the unit owner's authorized representative requests to inspect.~~
- e.c. **Unit Owner Information.** Each written request shall contain the name of the unit owner who is making the request for inspection, the address of the unit, and a telephone number where the person who is making the request may be reached during normal business hours. If a written request is made by an authorized representative (i.e., attorney, C.P.A., etc.), the request shall contain all of the above, plus the identity of the authorized representative. ~~-This~~

will enable a representative of the Board of Administration to confirm the appointment for inspection of the records.

- f.d. Hours of Inspection.** The records of the Association shall be open for inspection at the abovementioned location during the hours of ~~10:00 a.m.~~ 10:00 AM and ~~4:00 p.m.~~ 2:00 PM., Monday through Friday, except when these days fall on a legal holiday. Inspections must conclude by 4:00 PM.
- g.e. Limitations.** Inspection of the official records of the Association shall be limited to no more than one (1) occasion per calendar month for each unit, as represented by the unit owner or the unit owner's authorized representative. -Additionally, each period of inspection shall be no longer than two (2) hours in length.
- h. ~~Reproduction Costs.~~** ~~A unit owner may make or obtain copies of the records that are the subject of the unit owner's inspection at the charge of \$.25 per page, or such higher charge as may be allowed by law.~~

## 21. Unit Owner Participation at Unit Owner Meetings.

- a. Written Request.** All questions or requests to speak at a unit owner meeting shall be in writing and shall specify ~~the a specific~~ agenda item(s) or items to be addressed. All requests to speak at a unit owner meeting shall be received at the address specified in Rule 11 above The request must be delivered to the Association at 2069 World Parkway Boulevard East, Clearwater, FL. 33763 or emailed to associationinfo@otowfl.net no less than the greater of seventy two (72) hours or three (3) business days prior to the unit owner meeting.
- b. ~~Notice of Participation Request.~~** ~~All requests to speak at a unit owner meeting shall be received at the address specified in Rule 11 above no less than the greater of seventy two (72) hours or three (3) business days prior to the unit owner meeting.~~
- c.b. Topic of Participation.** Unit owners shall only be permitted to speak on specific agenda items, as reflected in the posted notice of the unit owner meeting; and shall be limited to comments, opinions, or questions on the specific agenda items as identified in the written request. ~~-A unit owner who so desires to speak on a given agenda item or items may speak for a cumulative maximum time of three (3) minutes during each meeting; and A unit owner who so desires to speak on a given agenda item may only address the a particular agenda item one time during each the meeting.~~ Participants must be recognized by the Chairperson before being permitted to speak. The Board of Administration will not participate in a debate with any unit owner.
- d. ~~Limitation on Participation.~~** ~~A unit owner who so desires to speak on a given agenda item may only address the particular agenda item one time during each meeting.~~
- e. ~~Length of Participation.~~** ~~A unit owner who so desires to speak on a given agenda item or items may speak for a cumulative maximum time of three (3) minutes during each meeting.~~
- f.c. Board Discussion.** After all unit owners who filed their written requests with the ~~association~~ Association ~~the greater of seventy two (72) hours or three (3) business days~~ prior to the



meeting have had an opportunity to speak on the particular agenda item ~~which was contained in the written request~~, the Board may discuss that item and said discussion shall be without interruption from the floor.

g. ~~**Recognition by Chairperson.** Participants must be recognized by the Chairperson before being permitted to speak.~~

**h.d. Prohibited Activities.** Shouting, profanity, or comments of a slanderous or derogatory nature, or otherwise disrupting the meeting, shall not be permitted. ~~Participants engaging in this type of conduct~~ may be asked to leave the meeting and are subject to any and all available legal remedies.

## 22. Unit Owner Participation at Board of Administration and Committee Meetings.

a. **Written Request.** All questions or requests to speak at a Board of Administration or committee meeting shall be in writing and shall specify ~~the a specific~~ agenda item(s) ~~or items to be addressed.~~ All requests to speak at a Board of Administration or committee meeting shall be received at the address specified in Rule 11 above The request must be delivered to the Association at 2069 World Parkway Boulevard East, Clearwater, FL. 33763 or emailed to associationinfo@otowfl.net no less than the greater of twenty four (24) hours or one (1) business day prior to the Board of Administration or committee meeting.

b. ~~**Notice of Participation Request.** All requests to speak at a Board of Administration or committee meeting shall be received at the address specified in Rule 11 above no less than the greater of twenty four (24) hours or one (1) business day prior to the Board of Administration or committee meeting.~~

c. **Topic of Participation.** Unit owners shall only be permitted to speak on specific agenda items, as reflected in the posted notice of the Board of Administration or committee meeting; and shall be limited to comments, opinions, or questions on the specific agenda item(s) identified in the written request. ~~A unit owner who so desires to speak on a given agenda item or items may speak for a cumulative maximum time of three (3) minutes during each meeting; and A unit owner who so desires to speak on a given agenda item may only address the a particular agenda item one time during each the meeting.~~ Participants must be recognized by the Chairperson before being permitted to speak. The Board of Administration or committee will not participate in a debate with any unit owner.

d. ~~**Limitation of Participation.** A unit owner who so desires to speak on a given agenda item may only address the particular agenda item one time during each meeting.~~

e. ~~**Length of Participation.** A unit owner who so desires to speak on a given agenda item or items may speak for a cumulative maximum time of three (3) minutes during each meeting.~~

f. **c. Board or Committee Discussion.** After all unit owners who filed their written requests with the Association ~~the greater of twenty four (24) hours or one (1) business day prior to the meeting~~ have had an opportunity to speak on the particular agenda item ~~which was contained in the written request~~, the Board or committee may discuss that item and said discussion shall be without interruption from the floor.

~~g. **Recognition by Chairperson.** Participants must be recognized by the Chairperson before being permitted to speak.~~

**h.d. Prohibited Activities.** Shouting, profanity, or comments of a slanderous or derogatory nature, or otherwise disrupting the meeting, shall not be permitted. Participants engaging in this type of conduct may be asked to leave and are subject to any and all available legal remedies.

~~1. Encumbrances and Community Service Fee.~~

~~b) Limitation on Encumbrances. No owner may mortgage or otherwise encumber his or her unit or any interest in it without the written approval of the Association, except to a national bank, state bank, life insurance company, federal savings and loan association or seller of the unit. Total mortgage debt, home equity loans and other indebtedness secured by liens encumbering any unit may not at any time exceed neither~~

~~2. the limit set forth in the applicable Declaration of Condominium; nor~~

~~3. an amount equal to sixty five percent (65%) of the lesser of (a) the purchase price paid for the unit by the owner, or (b) the appraised value of the unit as certified in writing by a Florida licensed real estate appraiser.~~

~~**Payment of Community Service Fee.** From time to time the Association may designate the method of payment of the Community Service Fee, Assessments, Lease Payments or other amounts payable to the management company. Effective for all acquisitions of units occurring after June 24, 2004, and continuing thereafter unless and until otherwise designated by the Association, the method of payment shall be by electronic transfer, also known as automated clearinghouse debit or auto debit, from a U.S. Bank in U.S. Dollars.~~

~~4. Activity Cards. The right to use the recreation facilities is limited solely to the current lawful occupants of the unit (i.e., the owners or any renters approved by the Association in accordance with Rule 10 entitled "Leasing and Sales of Units.") Activity Cards will be issued solely to owners who reside full time or part time in their units, upon presentation of proof of ownership, or to renters who have been approved by the Association pursuant to Rule 10. Activity Cards must be presented upon request while utilizing the recreational facilities. An owner or approved renter with a valid Activity Card must accompany any guest using any recreational facilities. Simultaneous usage by a unit owner and a tenant of the recreation facilities is prohibited. To obtain a new Activity Card, to renew a current Activity Card, or to have a replacement Activity Card issued, please see the Community Service Office and bring with you a current driver license or other government issued ID card, a current piece of mail with your unit address, and remit the appropriate fee (see Fee Schedule in Exhibit C).~~

**23. Approvals and Consents.** Any approval or consent of the Association required to be obtained by these Rules may be granted, denied, or conditioned, or for cause withdrawn, by the Association in its sole and absolute discretion; provided, however, that any such grant, denial, condition, or withdrawal shall not violate any applicable law. **In order to be effective, an approval or consent of the Association must be written and signed by at least two (2) officers of the Association.**

**24. Enforcement.** The Association shall be entitled to collect from any person or entity that violates these Rules any and all expenses incurred by the Association in enforcing these Rules and in preventing, correcting, or abating any such violation, including but not limited to reasonable attorneys fees and court costs. -The Association may also seek the assistance of local law enforcement officials to prevent, correct, or abate any violation of these Rules or applicable law. ~~Each owner shall be responsible for the condition of the owner's unit regardless of (1) any delegation of responsibility the owner may have made; or (2) whether a prior owner of occupant may have contributed to the condition of the unit.~~

**25. Severability.** If any provision of these Rules or the application thereof to any person or circumstance shall be invalid or unenforceable, the remainder of these Rules and the application of such provision to all other persons and circumstances shall not be affected thereby and shall continue in full force and effect.

**26. Prior Rules Superseded.** These Rules supersede and replace all prior rules and regulations promulgated by the Association.

**27. Reasonable Accommodation and Modification Practices and Policies.** The application, interpretations, and enforcement of these Rules are subject to reasonable accommodation and modification laws and the related practices and policies adopted and amended from time to time by the Board.

**28. Schedule of Fees.** Attached hereto as Exhibit "C" and constituting part of these Rules is a schedule of fees and charges to be levied by the Association in connection with specified services or circumstances. The Association shall have the discretion to waive or reduce any fee in any particular case if, in the opinion of the Association, it is justified by hardship or other special circumstance.

**EXHIBIT “A”**  
**TO**  
**~~SECOND-THIRD~~ AMENDED AND RESTATED RULES OF**  
**ON TOP OF THE WORLD CONDOMINIUM ASSOCIATION, INC.**

**Community Standards for Alterations or Additions to the Common Areas**

~~1. — Background Statement.~~ One of the functions of the Association is to review and approve or disapprove plans for all proposed alterations or additions to the Common Areas of On Top of the World. The Association has broad discretionary powers regarding the design, construction, and installation of any alterations or additions to the Common Areas, including, but not limited to, architectural style, color, texture, materials, landscaping, overall impact on surrounding property, and other aesthetic and non-aesthetic considerations. By this rule, the Association seeks to assure that On Top of the World remains a community of quality buildings that retain their tasteful and aesthetically pleasing architectural designs, their simple elegance in architectural character, their compatibility with each other, and their harmony with surrounding structures and topography. ~~;~~ The Association and to promotes the use of long-lasting materials and high standards of construction and installation so that any modifications to the Common Areas do not detract from the quality and permanence of this premiere condominium community.

This rule serves as a guide for owners and their contractors in making alterations or additions to the Common Areas. This rule does not include all building, use, and other restrictions applicable to On Top of the World. In addition to applicable laws and codes, alterations and additions to the Common Areas are governed by the applicable terms of each Declaration of Condominium and the Articles of Incorporation and By-Laws of the Association. Accordingly, the owners must also familiarize themselves with applicable laws and codes and the provisions of the governing documents for On Top of the World. The application, interpretation, and enforcement of this rule is subject to the Association’s reasonable accommodation policies and practices and applicable law. The inclusion of any recommendation in this rule shall not preclude the Association from disapproving any proposed alteration or addition that incorporates that recommendation.

1. ~~2. — Approval and Application Requirements.~~ No alteration or addition to the Common Areas may be made by any owner unless and until the owner has submitted and obtained the Association’s approval of an Application for Modification/Alteration (“**Application**”). This form may be obtained in the ~~Service—Department~~Community Service Office or on-line at [www.otowclearwaterinfo.com](http://www.otowclearwaterinfo.com). Please allow ten (10) to fifteen (15) days for the processing of the Application after it has been completed, signed, and delivered to the Association, together with any required supporting documentation or information. Review by the Association does not constitute approval. In order to be effective, an approval must be provided by the Association, in writing, and accompanied by a permit issued by the Association. This permit must be displayed on the exterior of the applicable unit at all times until the work has been completed and approved by the Association. Approval by the Association does not constitute approval by any public permitting agency. Pinellas County requires building permits for structural alterations or additions, which will necessitate compliance with applicable local and state building codes. In addition, before any digging is commenced, the owner or the owner’s contractor must obtain a satisfactory clearance from Sunshine State One Call at 1-800-432-4770.

2. ~~3.~~ **Responsibility and Expense.** The ~~applicable~~ unit owner and each subsequent owner of that unit, at his, her, or its expense, shall be solely responsible for the construction, installation, maintenance, repair, and replacement of all owner-added alterations and additions to the Common Areas. All alterations, renovations, and modifications to any unit or the common elements made or contracted for by any unit owner or occupant may be carried out only during the hours of ~~9:00 a.m.~~ **8:00 AM** to ~~6:00 p.m.~~ **5:00 PM** ~~on~~ Monday through Saturday.

3. ~~4.~~ **Petition to the Board.** If an Application is ~~disapproved~~ **not approved** by the Association and the owner desires to appeal the ~~disapproval to decision of~~ the Board, the following procedure shall be followed:

a. ~~(a)~~ The owner shall deliver to the Board a written request (the "Petition") for review of the ~~disapproval decision~~, which Petition shall state the reasons why the owner believes the requested alteration or addition complies with these Community Standards, ~~and the Unit~~ owner shall also provide all information necessary for the Board's consideration of the appeal ~~of the disapproval~~, including, but not limited to, a copy of the original Application.

b. ~~(b)~~ The Petition shall be delivered or mailed to the Board, in care of the ~~Association's Customer Service office~~ **Community Service Office**, at 2069 World Parkway Boulevard East, Clearwater, FL 33763.

c. ~~(c)~~ If the Board ~~does not overrule the Association's disapproval of the Application fails to approve the Petition~~ and does not grant approval of the Application (with such limitations, conditions, or requirements as may be deemed appropriate by the Board) within thirty (30) days from the Association's receipt of the Petition and supporting documentation, the ~~disapproval original decision~~ shall stand. ~~The foregoing provisions shall also apply to any appeal by any owner to the Board for reconsideration of any limitation, condition, or requirement imposed by the Board pursuant to the preceding sentence.~~

**5. Modification Standards for Alteration or Additions to the Common Areas.**

**1. (a) Antennae, Aerials, Satellite Dishes, and DBS Devices.** Every antenna, aerial, satellite dish ~~(each, a “Receiving Device”)~~ and direct broadcast satellite device (“DBS Device” ~~and together with Receiving Device, “Device”~~) ~~(each, a “Receiving Device”)~~ and related supports and hardware must be submitted to and approved by the Association prior to installation. -In order to preserve the architectural aesthetic of On Top of the World, no ~~Receiving~~-Device may be installed at the front, ~~or~~ side, ~~or rear~~ of any condominium building, ~~or on any Rear Base Building Line (Common Element Wall) of any condominium building on any common element wall~~, or on the roof of any condominium building. ~~Also, no~~**No** ~~Receiving~~-Device shall be placed in any position where it can create a safety hazard or potential nuisance.

Each ~~Receiving~~-Device that serves a first floor unit shall be installed behind the condominium building on the first floor patio. -Each ~~Receiving~~-Device that serves a second or third floor unit may be attached to the unit owner’s HVAC platform. -Each ~~Receiving~~-Device shall be ~~self supporting~~**self-supporting** and shall not require any ~~guy guide~~ wire to remain stable. -No ~~Receiving~~-Devices may exceed a height greater than two feet (2’) above the first floor patio or second or third floor HVAC unit platform. -All ~~Receiving~~ Devices and hardware by which they are secured must be able to withstand winds of up to one hundred twenty five (125) miles per hour. -Because the applicable laws and FCC rules and requirements change frequently, the Association may review the same at the time of application and, in the event of conflict between the regulatory requirements and these Rules, the regulatory requirements will control. -Please also refer to the “Mandatory Minimum Standards for Installation of a DBS Device or Antenna” attached hereto as ~~“Appendix A-1”~~, ~~which must be signed by each owner requesting approval for the installation of a Receiving Device or a DBS Device. The unit owner must complete a modification request and an “Indemnity Agreement for DBS Device or Antenna Installation” available at otowclearwaterinfo.com or in the Community Service Office.~~

**2. (b) Wall Art and Other Exterior Accessories, Furnishings and Fixtures.**

**a.** Unless otherwise ~~permitted~~**prohibited** by the Association, wall art is permitted in the ~~Common Areas only~~ inside ~~foyers~~ **common area corridors** and other portions of the condominium buildings not visible from the street. -Wall art must be submitted to and approved by the Association prior to installation. -Wall art may not exceed one (1) foot by one (1) foot.

**b.** All units must display unit numbers which shall be black in color and visible from the street.

**c.** Birdbaths, frog ponds, lawn sculptures, artificial plants, birdhouses, rock gardens, and other accessories, lawn furnishings and fixtures not part of the common elements of a condominium are prohibited in the Common Areas (except on individual patios). -Items of this nature placed or installed on individual patios should be aesthetically pleasing and either recognizably complement or acceptably contrast with their immediate surroundings, as determined by the Association. -All lawn furnishings and decorations shall be secured adequately or removed by the owner whenever there is a threat of severe weather.

**d.** ~~The foregoing or any other provision of these Rules to the contrary notwithstanding, any~~ **A** unit owner may display, without Association approval, one portable, removable United States flag in a respectful way. ~~and~~**In addition**, on Armed Forces Day,

Memorial Day, Flag Day, Independence Day, and Veterans Day, a unit owner may display in a respectful way, portable, removable official flags, not larger than 4 1/2 feet by 6 feet, that represent the United States Army, Navy, Air Force, Marine Corps, or Coast Guard. All portable flags must be displayed in such a way as not to create a safety concern or hazard. Additional standards regulating the installation and display of flags and flag poles are set forth on “Appendix A-2” attached hereto.

~~Additional standards regulating the installation and display of flags and flag poles are set forth on “Appendix A-2” attached hereto.~~

3. (e) **Second and Third Floor Hard Surface Floor Installations.** ~~No tile, wood or other~~ hard surface flooring may be installed in any second or third floor unit unless ~~it is approved by the Association prior to installation. The installation must include a sound absorbing underlayment approved by the an~~ Association. ~~A “2 in 1” or “3 in 1” moisture barrier has minimal sound absorption and will not be approved. The unit owner shall provide a receipt for the~~ approved sound-absorbing underlayment with an IIC of 72 or higher (1/4 inch cork may be used for tile installations) is installed. The unit owner shall provide a receipt for proof of purchase of the approved underlayment prior to commencing the installation. A “2-in-1” or “3-in-1” moisture barrier has minimal sound absorption and will not be approved. and the ~~The~~ unit owner shall permit inspection of the installed underlayment by an Association representative before it is covered by flooring.

4. (d) **Hurricane Shutters.** ~~The Board shall, from time to time, establish hurricane shutter specifications that comply with the applicable building code and establish permitted colors, styles, materials, and installation standards for hurricane shutters. Subject to the provisions herein, the Association shall approve the installation or replacement of hurricane shutters conforming to the specifications adopted by the Board. Any damage to the building structure or interior of the home resulting from either the installation of or the use of storm shutters shall be promptly repaired by the Owner. The Association shall have no obligation with respect to the installation of the shutters, and/or for the repair, replacement, and/or upgrade of the shutters. All hurricane shutters, supports, and other related hardware must be submitted to and approved by the Association prior to installation. Any support or other hardware that remains as a permanent element shall be finished to match the adjacent architectural element (i.e., stucco, window frame, trim band, etc.). -All shutters shall comply with the specifications set forth in Appendix A-3 attached to and constituting part of these Rules.~~

~~All hurricane shutters, supports and other related hardware must be submitted to and approved by the Association prior to installation. Any support or other hardware that remains as a permanent element shall be finished to match the adjacent architectural element (i.e., stucco, window frame, trim band, etc.). Shutter installations require a thirty five dollar (\$35.00) fee for post installation inspection. Please refer to Rule 15 of these Rules for additional details regarding the installation, waterproofing and use of hurricane shutters.~~

5. (e) **Window Awnings.** ~~Only foam core awnings are permitted. Awning modification requests must include the awning specifications and a licensed engineer’s seal attesting to the wind speed determination of the unit in the open position. -Awnings must be able to withstand a one hundred twenty-five 123 (125) mph-mile per hour wind speed in the open position. Retractable awnings must have a -wind sensor installed so that the awning will automatically close during high winds.~~

Retractable Awnings-awnings must ~~be remain~~ closed at the time a “hurricane watch” or any higher threat level warning is issued for Pinellas County ~~and must remain closed~~ until the hurricane watch and any higher threat level warning has been rescinded.

6. ~~(f)~~ **Fences.** No fence may be installed on any patio or other portion of the Common Areas unless it is approved by the Association prior to installation. -No fence may exceed four feet (4’) in height, and no fence may be installed on any front patio ~~without specific prior approval.~~ Fences shall be white in color and they shall be constructed of vinyl or powder coat aluminum in a style approved by the Association.- Fences must be installed on top of the concrete patio.- If the installation requires attachment to the common element wall, then prior to ~~commencing commencement, the installation,~~ the owner shall submit ~~payment for approval to the Association for a modification request along with payment for~~ caulking, sealing, and inspection.

7. ~~(g)~~ **Patios.** No patio may be installed in the Common Areas unless it is approved by the Association prior to installation. -Patios are prohibited on side walls of end units. ~~No screened enclosures are allowed.~~ Front patios may not extend more than five feet, four inches (5’4”5’4”) from the common element front wall of the condominium building. -Rear patios may not extend more than ten feet (10’10’) from the common element rear wall of the condominium building. -Although the patio length approved by the Association may vary, no patio may be installed within two feet (2’) from the nearest edge of a water meter bank, sprinkler head, or hose bib. -All patio installations must be inspected by a representative of the Association both before ~~the installation is commenced~~ and ~~again after it is complete~~ installation. Patio surface alterations to the originally-installed broom finish concrete must meet all applicable codes for slip resistance and the corresponding application must include the slip resistance specifications (wet & dry) from the manufacturer. Any paint or other surface Surface applications applied to any patio must be rated for a 0.50 or higher slip resistance and surfaces determined by the Association to be potentially hazardous are not permitted. In addition, No-screened enclosures are allowed not permitted.

8. ~~(h)~~ **Doors and Related Trim and Decorations.** No exterior door of any unit may be replaced unless the replacement door is approved by the Association prior to installation. -The preferred material for door trim and decorations are synthetic materials capable of maintaining their original appearance and providing optimum protection for its exposure. -The recommended material for exterior doors is fiberglass or steel with an Energy Star rating. -Doors with windows shall contain impact resistant glass or be glazed with missile resistant glass (.060 OVE inner layer). -Replacement doors must meet applicable wind load and impact ratings of the Florida Building Code. -Paint color for exterior doors must comply with the ~~original~~ building paint specification. -Storm doors (i.e., doors in front of the standard exterior door) must be white in color and meet all applicable Florida Building Codes.

9. ~~(i)~~ **Windows and Related Trim and Decoration.** No exterior window of any unit may be replaced unless the replacement window is approved by the Association prior to installation, ~~and no~~ ~~No~~ film or tint may be applied to any exterior window without the prior approval of the Association. Window film or tint must be impact resistant and non-reflective. Replacement windows must be of the same size as the original window being replaced. -The preferred material for window trim and decorations are synthetic materials capable of maintaining their original appearance and providing optimum protection for its exposure. -The recommended material for exterior windows is vinyl or aluminum with Low-E glass and an Energy Star rating. -Windows shall meet Miami-Dade County’s stringent requirements for impact resistance and adhere to all state and local building codes. -Jalousie



type windows are prohibited as replacement windows. -Exterior windows and related trim and decorations must be white in color. ~~Window film or tint must be impact resistant and non-reflective.~~

**10. Window Air Conditioners; and HVAC Replacement.** No window air conditioning unit may be installed in On Top of the World except when authorized in advance by the Association for a period not ~~exceeding to exceed~~ seven (7) days and only during HVAC repair or replacement. -Second and third floor HVAC compressor replacements must be installed with Association-approved compressor slab support frames. -Support frame specifications must be included with the Application. -Compressor weight should not exceed three hundred (300) pounds. -A sample support frame detail is attached hereto as ~~“Appendix A-3~~Appendix “A-4” for reference. -No HVAC compressor unit may be relocated without prior Association approval. -Air conditioning contractors must notify the ~~Service Department~~Inspection Services department located at the Community Service Office, of the date and time of installation for access to backyards. -An Association representative shall be present to guide and mark underground irrigation and sewer lines. -Before any digging is commenced, the owner or the owner’s contractor must obtain a satisfactory clearance of all other underground utilities facilities from Sunshine State One Call at 1-800-432-4770.

**11. ~~(k)~~ Water Softeners.** Water softeners must be resin, not ion exchange (salt). Installation through common walls is prohibited without the prior approval of the Association.

**12. ~~(l)~~ Exterior Lighting.** No exterior light fixture may be installed unless the proposed design and location of the light fixture are approved by the Association prior to installation. Light fixtures must be installed by licensed electricians. -Exterior light fixtures must be white or black in color.

**13. ~~(m)~~ Landscape.** No alteration or addition to the landscape or any landscape material in the Common Areas of On Top of the World, ~~including, but not limited to, any planting, trimming or removal of any tree or shrub or the alteration of the grade,~~ may be made without ~~the~~ prior written approval ~~of by~~ the Association. ~~-This includes, but is not limited to, any planting, trimming, or removal of any tree or shrub or the alteration of the soil grade.~~ If any alteration or addition to the landscape or landscape material ~~made by any owner~~ encroaches ~~at any time~~ upon any sidewalk, ~~neighbor’s patio,~~ or, parking area, ~~interferes may interfere~~ with the entry of light into any neighbor’s unit, interferes with the use or maintenance of any of the Common Areas, or is determined by the Association to constitute an unreasonable nuisance or hazard, ~~it~~ shall be removed by the owner or Management Company; at the owner’s expense, ~~upon the Association’s request.~~

**14. ~~(n)~~ Mailboxes.** Center core mailboxes may be replaced only upon prior approval by the Association and the replacement must be installed by a licensed postal mail box installer. Additional information regarding licensed installers may be obtained at the Community Service Office. Replacement mailboxes must also comply with applicable law and postal regulations.

**15. ~~(o)~~ Washers and Dryers.** A Pinellas County building permit and the approval of the Association is required for every washer and dryer installation in On Top of the World. Washers and dryers installed without a Pinellas County building permit are subject to substantial penalties and may be required to be removed by the owner, at the owner’s expense, by Pinellas County or the Association. Upon the transfer of ownership of any unit, a washer and dryer hook-up inspection must be completed by a licensed and insured electrician and plumber. If a washer and/or dryer conveys

with the sale, those appliances must be inspected by a certified appliance inspection service. Receipts must be provided to Inspection Services after each inspection.

16. ~~—————(p)—————~~ **Electrical.**

a. ~~—————(i)—————~~ **Exterior.** No alteration or addition to any exterior electrical components may be made without the prior approval of the Association and, if approved, must be carried out by a licensed and insured electrician. -All one hundred twenty five (125) volt, single phase fifteen (15) and twenty (20) ampere receptacles must have ground fault interrupter protection in accordance with the National Electrical Code. -Every exterior electrical component installed by an owner must connect to that owner’s electrical panel and all wiring must be contained within the wall, with no exterior conduit.

b. ~~—————(ii)—————~~ **Interior.** Any maintenance, repair, replacement, or alteration of any owner’s electrical panel or any wiring within or serving any unit must be carried out by a licensed and insured electrician.

17. ~~—————(q)—————~~ **Irrigation.** Irrigation lines and sprinklers may be installed and maintained only by the Association. -No alteration or addition may be made by any owner to any irrigation line, pipe, or hose in On Top of the World without the prior approval of the Association. -Unauthorized installation of irrigation line, pipes, and/or hoses will be removed at the unit owner’s expense.

18. ~~—————(r)—————~~ **Water, Fire, and Mold and Mildew Remediation.** ~~No mold or mildew remediation work involving any water, fire, and/or mold remediation or repair to any common element or within any unit, or involving remediation or repair to any area or areas exceeding an aggregate of ten (10) square feet, may be made is not permitted~~ without the prior approval of the Association ~~and, if required by the Association, an inspection of the affected portion of the unit by a representative of the Association.~~ Prior to commencing any remediation or repair requiring Association approval under this paragraph, the unit owner must provide to the Association a remediation plan strictly adhering to the Institute of Inspection, Cleaning and Restoration Certification IICRC S520 Standard and Reference Guide for Professional Mold Remediation and, upon Upon completion of the remediation or repair, ~~the unit owner shall provide to the Association~~ it is highly recommended the unit owner provide a clean air quality test to the Association. Depending upon the size and scope of the project, a clean air quality test may be requested by the Association.

19. ~~—————(s)—————~~ **Walkways, Stairwells, and Balconies.** No alteration or addition to any walkway, stair, stairwell, or balcony may be made, ~~without the prior approval of the Association.~~ Any surface addition to the originally installed broom finish concrete must meet all applicable codes for slip resistance, and the corresponding Application must include the slip resistance specifications (wet & dry) from the manufacturer. ~~Unit owner surface additions which have become faded or worn shall be refinished or removed by the unit owner, at the unit owner’s expense.~~

~~—————(t)—————~~ **Parking Spaces.** ~~No stop block may be placed in any parking space without the prior approval of the Association. Street parking is available on streets not designated with “No Parking” signage. Visitor parking is on a first come, first served basis and is not intended for indefinite use by one party.~~

20. ~~—————(u)—————~~ **Hand Rails.** No handrail may be installed in the Common Areas without the prior approval of the Association. -All handrails must meet all applicable codes.

21. ~~(v)~~ **Interior Renovation and Remodeling.** No interior renovation or remodeling of any unit which involves any alteration or addition to any water pipe, sewer pipe, or electric wiring, or any alteration or addition to any common element of the building may be made without the prior approval of the Association. -Owners are reminded that interior modifications may also require a permit from the Pinellas County Building Department.

22. ~~(w)~~ **Common Element Wall Penetrations.** No penetration into or through any common element wall or boundary may be made unless it is approved in advance by the Association.

23. ~~(x)~~ **Contractors.** Every contractor engaged by a unit owner to construct or install any alteration or addition to Common Area or unit must provide to the Association a copy of a current contractor or business license, as applicable, a current certificate of competency, proof of insurance in an amount not less than One Million Dollars (\$1,000,000) in general liability coverage, and proof of workers compensation insurance or an exemption card. -All insurance must be current and kept current for so long as the contractor is working in On Top of the World.

24. ~~(y)~~ **Debris Removal.** All debris generated by any alteration or addition to the Common Areas or any renovation or remodeling of a unit must be properly disposed of by the owner's contractor, at the applicable owner's or contractor's expense. -No appliances, bulk items, or construction debris may be deposited in the trash, storage rooms, or in Common Areas (curbside) in On Top of the World. -Upon the failure of an owner or the owner's contractor to comply with this rule, the Association shall have the right to ~~cause the offending debris to be removed and disposed~~remove and dispose of, the debris and to ~~levy a charge against the applicable owner responsible. for the~~The cost so incurred by the Association, ~~plus an overhead charge of a~~ twenty-five percent (20%)(25%) overhead charge will be the responsibility of the unit owner to pay.

25. ~~6.~~ **No Liability.** ~~None of the~~The Association, ~~the~~ members of the Board, the Management Company, or any officer, director, employee, or agent of the Association or the Management Company shall not have any liability to anyone for any action or failure to act by any of them with regard to any matter addressed by ~~this rule~~these rules. -The publication and enforcement of these guidelines and any approvals granted pursuant to ~~this rule~~these rules shall be deemed solely for the purpose of protecting and enhancing the aesthetic qualities of On Top of the World, and they shall not be construed as a warranty, representation, or covenant that these guidelines or any approved activity will, if followed, result in alterations or additions that are safe or that will comply with applicable law or any building, fire, or safety code.

**APPENDIX A-1**  
**TO**  
**THIRD AMENDED AND RESTATED RULES OF**  
**ON TOP OF THE WORLD CONDOMINIUM ASSOCIATION, INC.**

**Mandatory Minimum Standards for Installation of a DBS Device or Antenna**

The purpose of these Minimum Standards is to assure the safety of residents and surrounding properties from installation of devices designed to receive direct broadcast satellite signal (“DBS”) which are one meter in diameter or less, and for antennas.

As used herein, “DBS installation” shall mean the reception device and its means of mounting. “Antenna” shall mean devices designed to receive television broadcast signals. -“Rear Base Building Line” shall mean the back wall of any dwelling, including any appurtenance attached to the dwelling either as a part of the original construction, or as an addition, including, but not limited to, screen rooms or sun-rooms.

It is the obligation of the owner to seek Association approval pursuant to the Condominium Documents, By-laws, and Rules & Regulations. -All Applications for such approval must clearly show that the DBS or antenna installation shall not violate any of the provisions of the Condominium Documents, By-laws, and Rules & Regulations. -Approvals will not be granted unless the installation is in full compliance with all Condominium Documents, By-laws, and Rules & Regulations and with these Minimum Standards.

**Prior to installation,**~~the~~ **The** owner shall demonstrate to the satisfaction of the Association or its designee, that the DBS installation or antenna can withstand wind speeds up to **one hundred twenty-five (125) mph/miles per hour.** -Owner agrees to indemnify and hold harmless the On Top of the World Condominium Association, Inc. and Parkway Maintenance ~~and~~ **& Management, Co Pinellas, LLC.** (Management Company) for any damage which may result to the installation in the normal course of maintenance work, as described in the Condominium Documents, By-laws, and Rules & Regulations, for maintenance work around the dwelling; and for any liability whatsoever from damage resulting to surrounding dwellings as a result of failure of an installation. -No approval shall be given until Owner(s) has/have executed an indemnity agreement pursuant to this paragraph.

~~For Installation at First Floors:~~**First Floor Installation.** All DBS or antenna installations shall be installed on patios behind the dwelling on the 1st floor patio in order to preserve the architectural aesthetic of the community. -Installation at the front or side of a dwelling or on Rear Base Building Lines (Common Element or Walls) is specifically prohibited. -Antennas shall be self-supporting and must be able to safely withstand high winds and tropical weather. -Antennas shall require no **guy-guide** wires to remain stable. ~~Guy-Guide~~ wires constitute a danger to ground maintenance workers.

~~For Installation on Second and Third Floors:~~**Second and Third Floor Installation.** DBS devices may be attached to the unit owner’s HVAC slab and is subject to the following limitations: Attachment shall be by the use of hardware capable of securing the DBS installation against ~~winds~~ **wind speeds** up to **one hundred twenty-five (125)** miles per hour. -DBS installation may not extend to a height greater than two (2) feet above the HVAC unit. -Antenna shall be ~~self-supporting~~ **self-supporting**, requiring no **guy-guide** wires to remain stable.

Accepted this \_\_\_\_ day of \_\_\_\_\_, 20\_\_\_\_.

Owner: \_\_\_\_\_

Owner: \_\_\_\_\_

INDEMNITY AGREEMENT FOR DBS DEVICE OR ANTENNA INSTALLATION

~~The undersigned, having requested approval of the On Top of the World Condominium Association for the privilege of installing a DBS device pursuant to the Mandatory Standards for DBS Device Installation and Antennas, does hereby ratify the provisions of those standards and does further agree that the undersigned shall indemnify and hold harmless On Top of the World Condominium Association and/or Parkway Maintenance and Management, Co. (Management Company) and any and all of its agents and employees from any loss or damage as a result of the installation and/or maintenance or operation of any DBS Device or Antenna installation. This indemnification agreement shall obligate the owner(s) to reimburse the Association or Management Company or any of its agents and employees for all costs and expenses including attorney's fees, which may be expended with regard to any claim regarding said DBS Device or Antenna Installation or operation or maintenance.~~

Accepted this \_\_\_\_ day of \_\_\_\_\_, 20\_\_\_\_.

Owner: \_\_\_\_\_

Owner: \_\_\_\_\_

Address: \_\_\_\_\_

\_\_\_\_\_

Bldg \_\_\_\_\_ Unit \_\_\_\_\_

**APPENDIX A-2**  
**TO**  
**THIRD AMENDED AND RESTATED RULES OF**  
**ON TOP OF THE WORLD CONDOMINIUM ASSOCIATION, INC.**

**Additional Standards Regulating Installation and Display of Flags and Flag Poles**

- **Prohibited Locations.** Flags may not be affixed to railings or balustrades.
- **Rear Patio Installations.** Flag poles installed on rear patios may not exceed ~~20~~ twenty feet (20') in height and must be able to withstand winds of up to one hundred twenty-five (125) miles per hour. Poles may not be installed so as to impede scheduled or emergency maintenance. -In order to install a flag pole on a rear patio, the owner must submit an Application for Modification to a common element. Applications are ~~(available~~ online at otowclearwaterinfo.com or by visiting the Service Department~~Community Service Office~~). ~~An inspection-modification~~ fee of \$35.00 must accompany each application. -The owner is responsible for installing and maintaining the flag pole and any flag, at the owner's expense.
- **Front Installations.** In order to display an American flag or other permitted flag on the front of a unit, the owner must submit an Application for Modification to a common element. Applications are ~~(available~~ online at otowclearwaterinfo.com or by visiting the Service Department~~Community Service Office~~. A modification fee of \$35.00 must accompany each application, along with ~~A a~~ bracket or anchor installation fee of \$10.00 ~~must accompany each application~~. -Owners will be contacted by the Management Company for installation. -Flags ~~will~~ must be installed vertically on the common element wall outside the unit, in compliance with federal regulations for flag display, Chapter 718, *Florida Statutes*, and the waterproofing warranty on each building. -The installation fee covers labor and materials for the installation of the bracket or anchor for the flag. -The owner is responsible for installing and maintaining the flag, at the owner's expense.

APPENDIX A-3

Sample Support Frame Detail

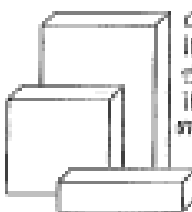
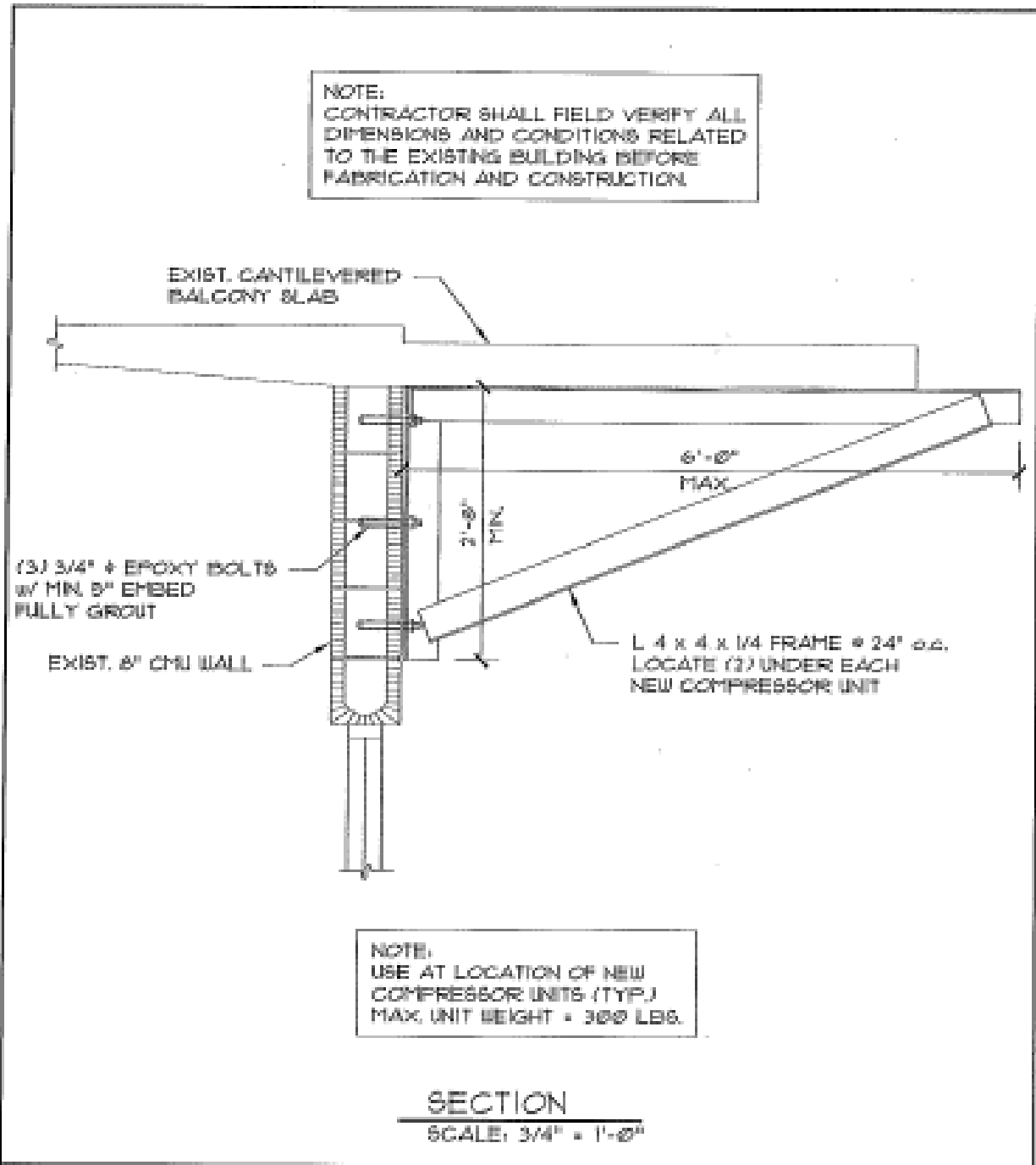

center for  
innovative  
structures,  
inc.

3785 S. MacDill Avenue  
Tampa, FL 33611  
813-835-3311  
FAX 813-835-8503

Structural Engineers

|          |                                   |
|----------|-----------------------------------|
| CLIENT:  | <u>ON TOP OF THE WORLD</u>        |
| PROJECT: | <u>CLEARWATER COMPRESSOR SLAB</u> |
| DATE:    | <u>10/13/06</u>                   |
| DRAWING: | <u>SK-1</u>                       |



**EXHIBIT "B" APPENDIX A-3**  
**TO**  
**SECOND-THIRD AMENDED AND RESTATED RULES OF**  
**ON TOP OF THE WORLD CONDOMINIUM ASSOCIATION, INC.**

**Hurricane Shutter Specifications**

**Type**:. ———Track mounted removable panel that fit within the masonry or frame opening and tracks that are permanently anchored into the precast lintel and filled masonry units flanking a window opening; or track mounted rollaway shutters permanently attached to the precast lintel and filled masonry units flanking a window opening. Any other material or storm shutter system shall require specific written approval by the Association.

**Material**:. —Galvanized metal, Lexan (clear), powder coated steel or aluminum.

**Panel Color**:. ———White, clear, or galvanized finish. Color shall be factory applied.

**Track Color**:. ———White, factory applied.

**Attachment**:. ———Anchor bolts or other means of attachment shall be non-ferrous or stainless steel and in conformance with shutter manufacturer's specifications. In no case shall anchor strength be less than 2,400 lbs. pull out and 1,500 lbs. shear for concrete lintel or column, and not less than 1,220 lbs. shear when installed in a frame opening.

Shutter system shall be in conformance with the ~~Metro-Miami--~~Dade Standards PA202-94, PA201-94 and PA203-94. Installation shall be capable of withstanding sustained wind speeds in excess of ~~120-one~~ hundred twenty-five (125) mph miles per hour.

No wall penetration shall be made into hollow concrete block or at any location other than within the masonry or frame opening.

All wall penetrations shall be sealed at the time of installation with urethane caulking compound conforming to (specification) or other caulking compound approved by the Association. Track shall be caulked at all edges contacting masonry or frame opening with white caulking compound conforming to (specification).

**Approval/Inspection**:. ———Owner shall submit a ~~review-modification request~~ and ~~inspection~~-fee as determined by the Association with each Application (as defined in Exhibit "AC" to these Rules). ~~The initial fee shall be \$35.00.~~

**APPENDIX A-4**

**Sample Support Frame Detail**

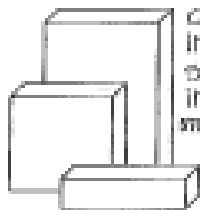
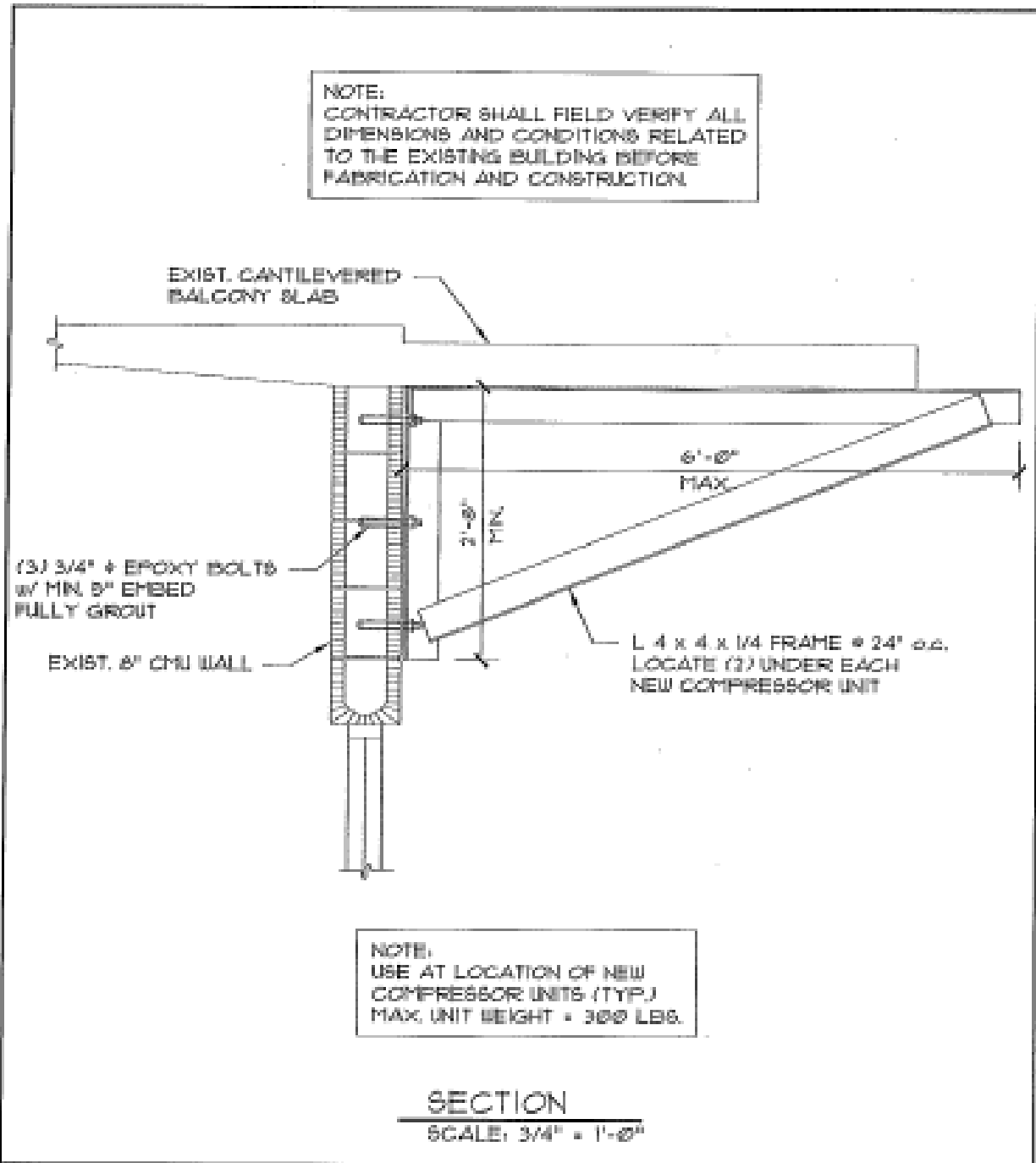

center for  
innovative  
structures,  
inc.

3750 S. MacDill Avenue  
Tampa, FL 33611  
813-635-5211  
FAX 813-635-8503

Structural Engineers

|          |                            |
|----------|----------------------------|
| CLIENT:  | ON TOP OF THE WORLD        |
| PROJECT: | CLEARWATER COMPRESSOR SLAB |
| DATE:    | 10/13/06                   |
| DRAWING: | SK-1                       |

~~EXHIBIT "D"~~~~EXHIBIT "B"~~  
TO  
SECOND~~THIRD~~ AMENDED AND RESTATED RULES OF  
ON TOP OF THE WORLD CONDOMINIUM ASSOCIATION, INC.

Methodology for Allocating Space in Storage Rooms

The Association will allocate to each unit in each building a portion of the floor area in the Storage Rooms in the that building by calculating the total available floor area in all Storage Rooms in that building, less a minimum three foot, six inches (3'6") times the length of each storage room for center access aisles, divided by the number of units in that building in order to arrive at the equal amount of net floor area to be made available to each unit in that building for storage. -The owner of any personal property placed in the Storage Rooms will bear all risk of loss. -The Association shall not be responsible to insure any personal property stored in the Storage Rooms.

Hypothetical Example: If a condominium building contains 72 units and the Storage Rooms in that building contain a total interior net floor area of 1,232 square feet (after first deducting the above mentioned center access aisle in each Storage Room), the 1,232 square feet of net floor area would be divided by the 72 units in order to yield approximately 17 square feet of net floor area to be assigned to each unit in that building.

**EXHIBIT "C"**  
**TO**  
**SECOND ~~THIRD~~ AMENDED AND RESTATED RULES OF**  
**ON TOP OF THE WORLD CONDOMINIUM ASSOCIATION, INC.**

**Schedule of Fees**

The following fees and charges shall be collected by, and paid to, the Management Company for the use and benefit of the Association:

| <u>Service or Circumstance</u>   | <u>Amount</u>   |
|--|---|
| <del>Condon Questionnaire or Response responding to request for information by or on behalf of a prospective purchaser or lien holder, other than that required by law</del>       | <del>\$ 150.00 plus photocopying cost and attorney's fees</del> |
| Condominium Documents  | \$50.00   |
| Application for Approval Processing Fee  |   |
| — (excluding lease renewal with same lessee)   |   |
| Single applicant   | 100.00 \$150.00   |
| Married couple   | 100.00 \$150.00   |
| Additional occupant  | 100.00 \$150.00   |
| Mold or Mildew Inspection  | 50.00   |
| Paradise Gate Access Card or Access Remote Control Bar Code  | 45.00 \$15.00   |
| Common Element Alteration or Addition Inspection Fee   | \$35.00   |
| Flag Bracket or Anchor Installation Fee  | \$10.00   |
| Mailbox Key (Replacement)  | \$14.00   |
| Assessment Estoppel Certificate (3 or more business days)  | 50.00   |
| Assessment Estoppel Certificate (less than 3 business days)  | 75.00   |
| <u>Estoppel Certificate</u>  |   |
| Within Ten (10) Business Days of Request, No Delinquent Amount Due   | \$250.00  |
| Within Ten (10) Business Days of Request, Delinquent Amount Due  | \$400.00  |
| Within Three (3) Business Days, No Delinquent Amount Due   | \$350.00  |
| Within Three (3) Business Days, Delinquent Amount Due  | \$500.00  |
| Copy Charge — B/W (per page)   | \$0.25  |
| Lead Paint Disclosure  | \$3.00  |
| Activity Card (New)  | \$3.00  |
| Activity Card (Replacement)  | \$25.00   |
| — (A replacement card is defined as a new card printed to replace a lost, damaged, or stolen card. All expired cards will need to be surrendered prior to a new card being issued) |   |
| On Top of the World License Plate  | 10.00   |
| Hurricane Shutters Inspection Fee  | 35.00   |
| Tile, Wood and Other Hard Surface Floor Inspection Fee   | 35.00   |
| Patio Inspection Fee   | 35.00   |
| Receiving Device (e.g., antenna or dish) Inspection Fee  | 35.00   |
| Door, Window, Exterior Trim, Decoration Inspection Fee   | 35.00   |

|   |   |
|---|---|
| <del>Fence Inspection Fee</del>   | <del>35.00</del>  |
| <del>Re-inspection/Correction Fee</del>   | <del>35.00</del>  |
| <del>Service or Circumstance</del>  | <del>Amount</del>   |
| <del>Returned Check or Rejected ACH Debit Service Charge:</del>   |   |
| <del>    Face value not over \$50</del>   | <del>\$25.00</del>  |
| <del>    Face value over \$50 but not over \$300</del>  | <del>\$30.00</del>  |
| <del>    Face value over \$300</del>  | <del>\$40.00 or 5% of the face</del>                                  |
|   | <del>amount, whichever greater</del>                                  |
| <del>Community Service Fee Late Charge:</del>   | <del>Greater of \$25.00 or 5% of the delinquent installment for</del> |
|   | <del>each Community Service Fee installment not received by</del>     |
|   | <del>the 15<sup>th</sup> day of the month in which due.</del>         |
| <del>After Hours Water Turn On Service Charge</del>   | <del>After Hours</del>  |
|   | <del>\$35.00</del>  |
| <del>(After 5:30 p.m. Mon-Fri, or after 11:30 a.m. Sat)</del>   |   |
| <del>Access Card (New)</del>  | <del>\$7.00</del>   |
| <del>Access Card (Replacement)</del>  | <del>\$25.00</del>  |
| <del>A replacement card is defined as a new card printed to replace a damaged, lost, or stolen card. There is</del> |   |
| <del>no charge to renew an existing card.</del>   |   |
| <del>Boat Storage Rental Fee</del>  | <del>\$50.00</del>  |
| <del>Common Element Attachment Caulking and Sealing</del>   | <del>\$10.00</del>  |
| <del>Modification Inspection Fee</del>  | <del>\$35.00</del>  |

~~**EXHIBIT "D"**~~  
~~**TO**~~  
~~**SECOND AMENDED AND RESTATED RULES OF**~~  
~~**ON TOP OF THE WORLD CONDOMINIUM ASSOCIATION, INC.**~~

~~Methodology for Allocating Space in Storage Rooms~~

~~The Association will allocate to each unit in each building a portion of the floor area in the Storage Rooms in the that building by calculating the total available floor area in all Storage Rooms in that building, less a minimum three foot, six inches (3'6") times the length of each storage room for center access aisles, divided by the number of units in that building in order to arrive at the equal amount of net floor area to be made available to each unit in that building for storage. The owner of any personal property placed in the Storage Rooms will bear all risk of loss. The Association shall not be responsible to insure any personal property stored in the Storage Rooms.~~

~~Hypothetical Example: If a condominium building contains 72 units and the Storage Rooms in that building contain a total interior net floor area of 1,232 square feet (after first deducting the above mentioned center access aisle in each Storage Room), the 1,232 square feet of net floor area would be divided by the 72 units in order to yield approximately 17 square feet of net floor area to be assigned to each unit in that building.~~

**EXHIBIT "C"**  
**TO**  
**THIRD AMENDED AND RESTATED RULES OF**  
**ON TOP OF THE WORLD CONDOMINIUM ASSOCIATION, INC.**

**Schedule of Fees**

The following fees and charges shall be collected by, and paid to, the Management Company for the use and benefit of the Association:

|   |          |
|---|----------|
| Access Card (New)   | \$7.00   |
| Access Card (Replacement)   | \$25.00  |
| <i>A replacement card is defined as a new card printed to replace a damaged, lost, or stolen card.<br/>There is no charge to renew an existing card.</i>                              |          |
| Activity Card (New)   | \$3.00   |
| Activity Card (Replacement)   | \$25.00  |
| <i>A replacement card is defined as a new card printed to replace a lost, damaged, or stolen card. All expired cards will need to be surrendered prior to a new card being issued</i> |          |
| Application for Approval Processing Fee:  |          |
| Single Applicant  | \$150.00 |
| Married Couple  | \$150.00 |
| Additional Applicant  | \$150.00 |
| Boat Storage Rental Fee   | \$50.00  |
| Common Element Alteration or Additional Inspection Fee  | \$35.00  |
| Common Element Attachment Caulking and Sealing  | \$10.00  |
| Condominium Documents   | \$50.00  |
| Condo Questionnaire or responding to request for information by or on behalf of a prospective purchaser or lien holder, other than that required by law                               | \$150.00 |
| Copy Charge – B/W (per page)  | \$0.25   |

|  |   |  |
|--|---|--|
| Estoppel Certificate:  |   |  |
| Within Ten (10) Business Days of Request, No Delinquent Amount Due |   | \$250.00   |
| Within Ten (10) Business Days of Request, Delinquent Amount Due    |   | \$400.00   |
| Within Three (3) Business Days, No Delinquent Amount Due           |   | \$350.00   |
| Within Three (3) Business Days, Delinquent Amount Due              |   | \$500.00   |
| Flag Bracket or Anchor Installation Fee                            |   | \$10.00  |
| Lead Paint Disclosure  |   | \$3.00   |
| Mailbox Key (Replacement)  |   | \$14.00  |
| Modification Inspection Fee  |   | \$35.00  |
| On Top of the World License Plate                                  |   | \$10.00  |
| Paradise Gate Bar Code   |   | \$15.00  |
| Re-inspection/Correction Fee                                       |   | \$35.00  |
| Water Turn On Service Charge - After-Hours                         |   | \$35.00  |
| Returned Check or Rejected ACH Debit Service Charge                |   |  |
| Face value not over \$50   |   | \$25.00  |
| Face value over \$50;but not over \$300                            |   | \$30.00  |
| Face value over \$300  |   | \$40.00 or 5% of the face amount, whichever is greater |
| Community Service Fee Late Charge                                  | Greater of \$25.00 or 5% of the delinquent installment for each Community Service Fee installment not received by the 15 <sup>th</sup> day of the month in which due. |  |

(Includes Amendments Approved by the Board of Administration on June 14, 2019) (when approved, date will be inserted)